

PARTS LIST

ITEM	PART #	DESCRIPTION	NOTES
1	K1391/94	Series 4 Single Face Access Body w/ Slide Cover	Assembly
2	1200	Series 2/3/4 Reveal	Attaches to the Body
3	K1333	Series 4 Square Post	Assembly
4	5433	Series 4 Square Post Cap	3/4" Reveal Tab
41	5040	Cap Screw	#10 countersink

NOTE: PRE-CUT KITS ARE NOT PRE-DRILLED.

(Holes shown in this drawing are for reference only. Drilling of pilot holes are to be done by fabricator.)

REVEAL SETTING OPTIONS

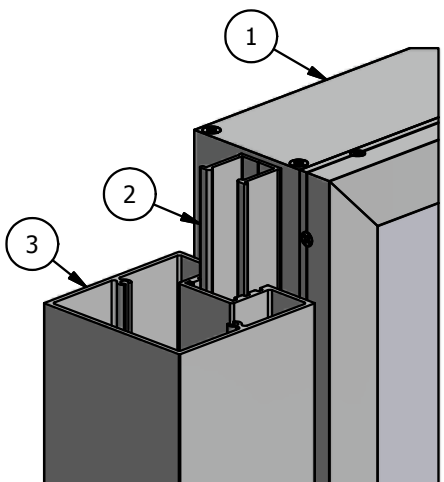
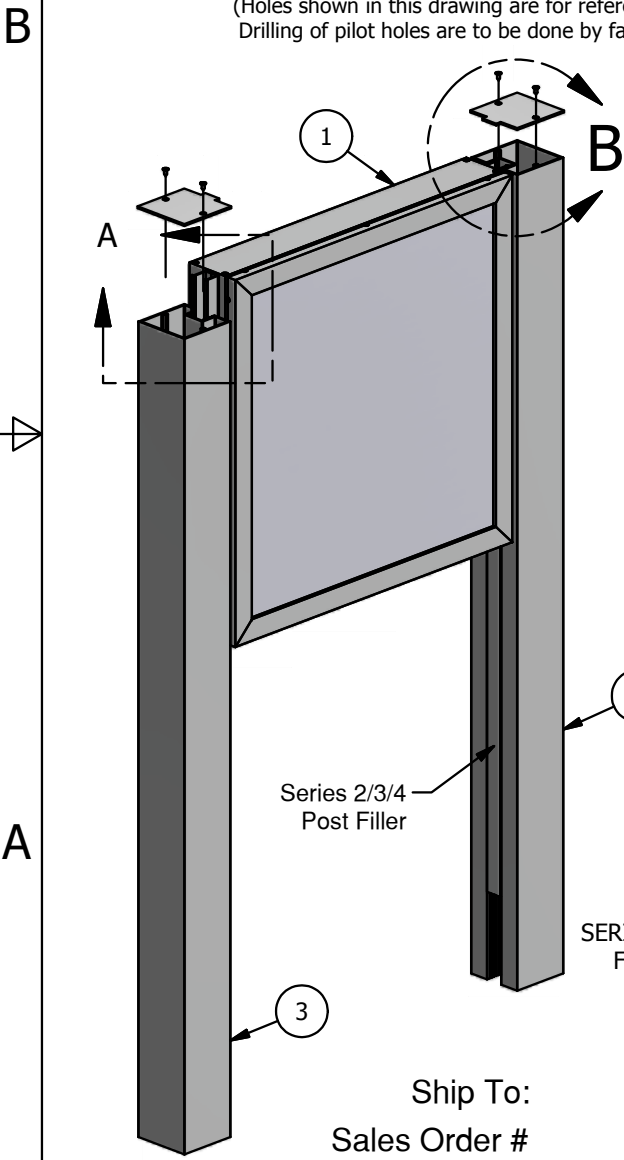
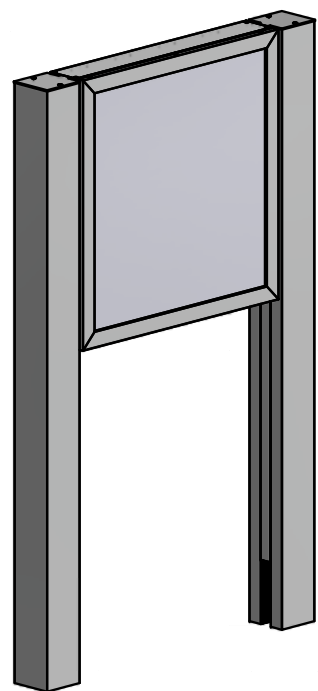
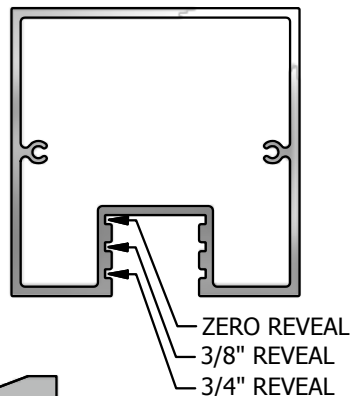

DETAIL A

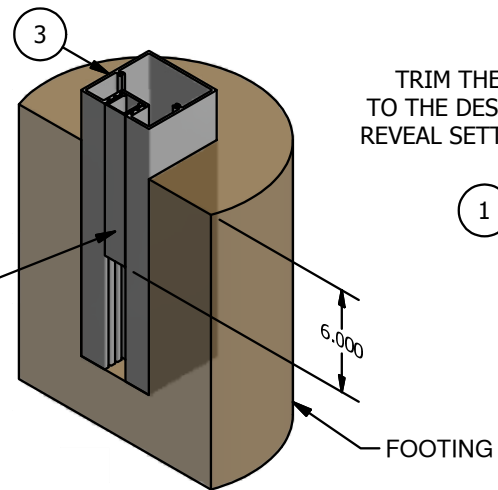

DETAIL B

TRIM THE TAB TO THE DESIRED REVEAL SETTING.

Ship To:
Sales Order #

THIS DRAWING WAS CREATED AT NO CHARGE TO ASSIST YOU IN VISUALIZING OUR PROPOSAL. THE DRAWING HEREIN IS THE PROPERTY OF SIGNCOMP. PERMISSION TO COPY OR REVISE THIS DRAWING OR TO USE THIS DRAWING FOR PRODUCTION IS STRICTLY PROHIBITED AND CAN ONLY BE COPIED, REVISED OR USED FOR PRODUCTION WITH THE EXPRESSED WRITTEN PERMISSION OF SIGNCOMP.

Project Name: Series 4 SF Access Body - Slide Cvr - 4" Sq Post - Assembly	Sheet: 1 of 1	Size: A	SignComp
Sign Company: K1391/94/33	Date: 5/15/2017	Drawing By: SBreihof	

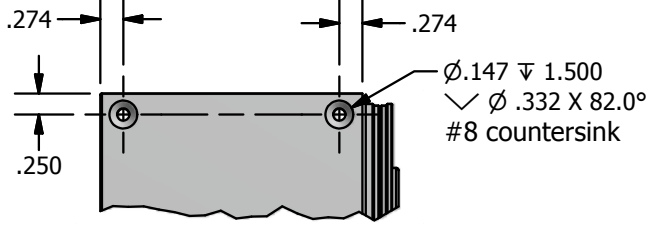

HOLE DETAIL
DRILLED BY OTHER

PARTS LIST			
ITEM	PART #	DESCRIPTION	NOTES
1	1391	Series 4 Single Face Access Body	Top & Bottom
2	1391	Series 4 Single Face Access Body	Sides
3	5340	Series 4 Access Body Corner Angle	One (1) per body corner
5		.063 Aluminum Back	By Other
60	5270	Access Body Corner Screw	See hole detail

NOTE: PRE-CUT KITS ARE NOT PRE-DRILLED.
 (Holes shown in this drawing are for reference only.
 Drilling of pilot holes are to be done by fabricator.)

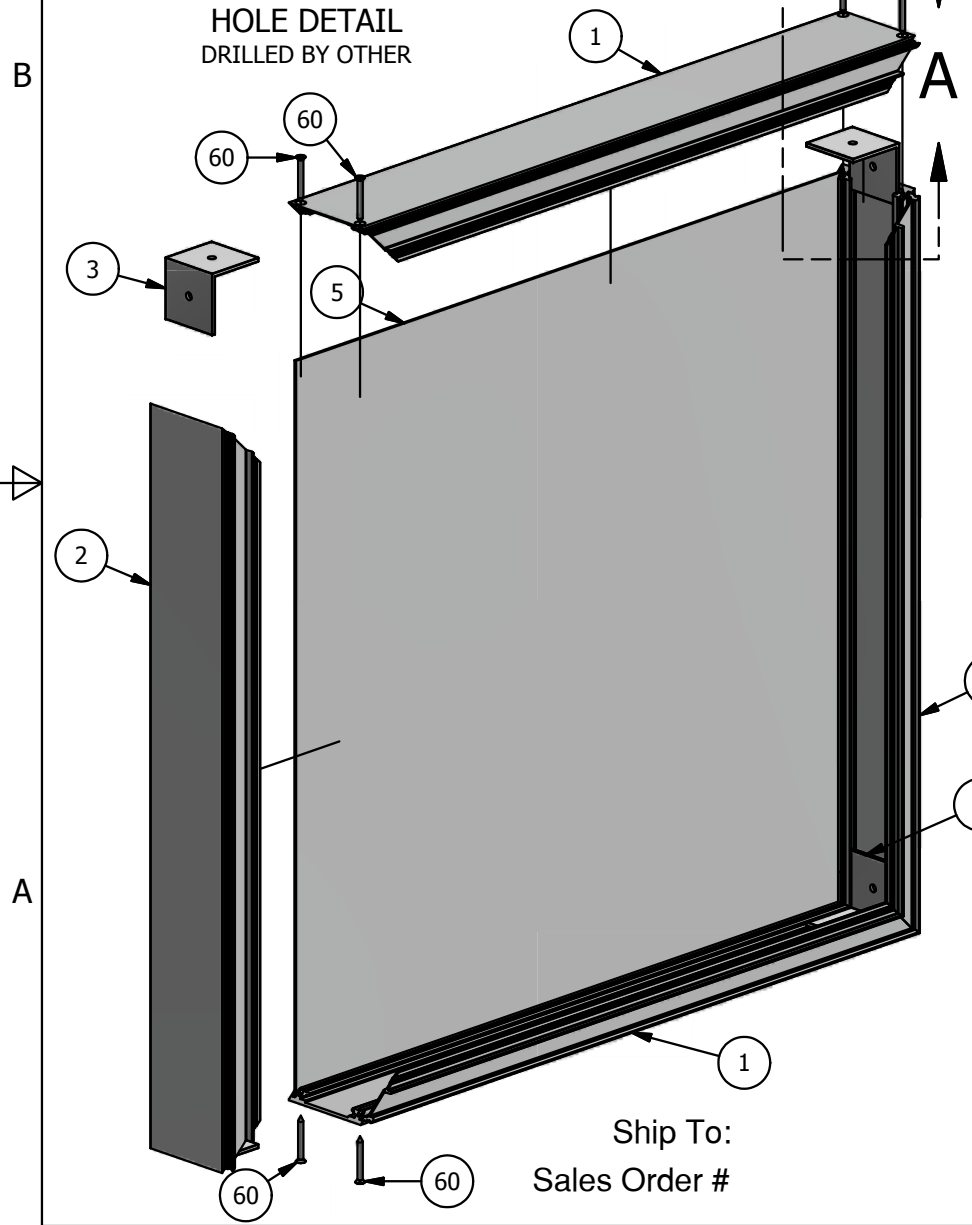

Ship To:
Sales Order #

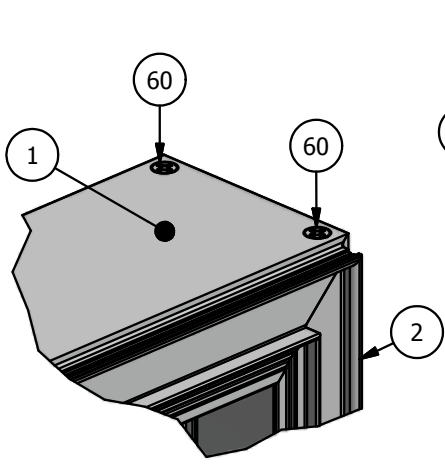

DETAIL A-2

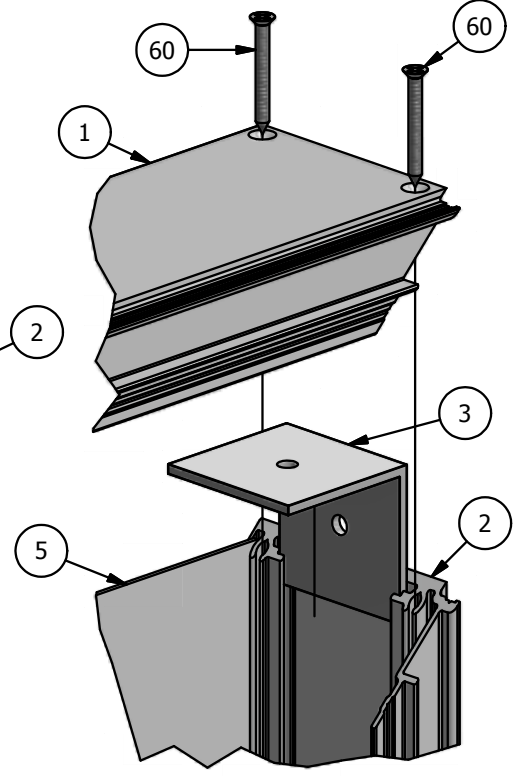

DETAIL A-1

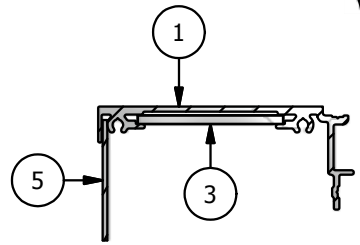

CABINET SECTION-VIEW

THIS DRAWING WAS CREATED AT NO CHARGE TO ASSIST YOU IN VISUALIZING OUR PROPOSAL. THE DRAWING HEREIN IS THE PROPERTY OF SIGNCOMP. PERMISSION TO COPY OR REVISE THIS DRAWING OR TO USE THIS DRAWING FOR PRODUCTION IS STRICTLY PROHIBITED AND CAN ONLY BE COPIED, REVISED OR USED FOR PRODUCTION WITH THE EXPRESSED WRITTEN PERMISSION OF SIGNCOMP.

Project Name: Series 4 Single Face Access Body
 Sign Company: K1391
 Revision:
 Date: 3/22/2017
 Sheet: 1 of 1
 Drawing By: SBreihof
 Size: A



2



1

PARTS LIST

ITEM	PART #	DESCRIPTION	NOTES
1	K1391	Series 4 SF Access Body	Assembly
2	1694	Slide Cover	All Sides
3	5210	Corner Key	One (1) per corner
63	5168	Slide Cover Screw	Drill #8 countersink

NOTE: PRE-CUT KITS ARE NOT PRE-DRILLED.

(Holes shown in this drawing are for reference only. Drilling of pilot holes are to be done by fabricator.)

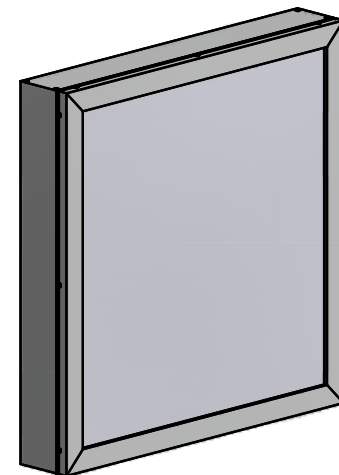
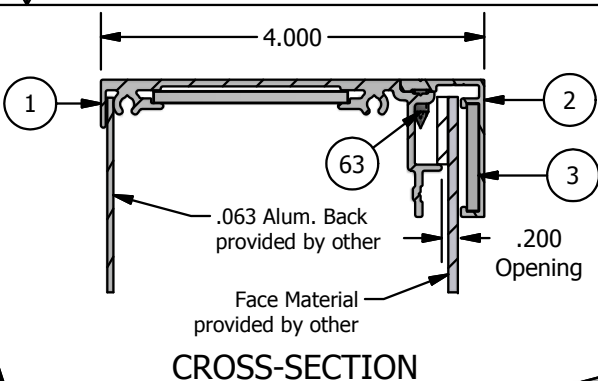

B

A

B

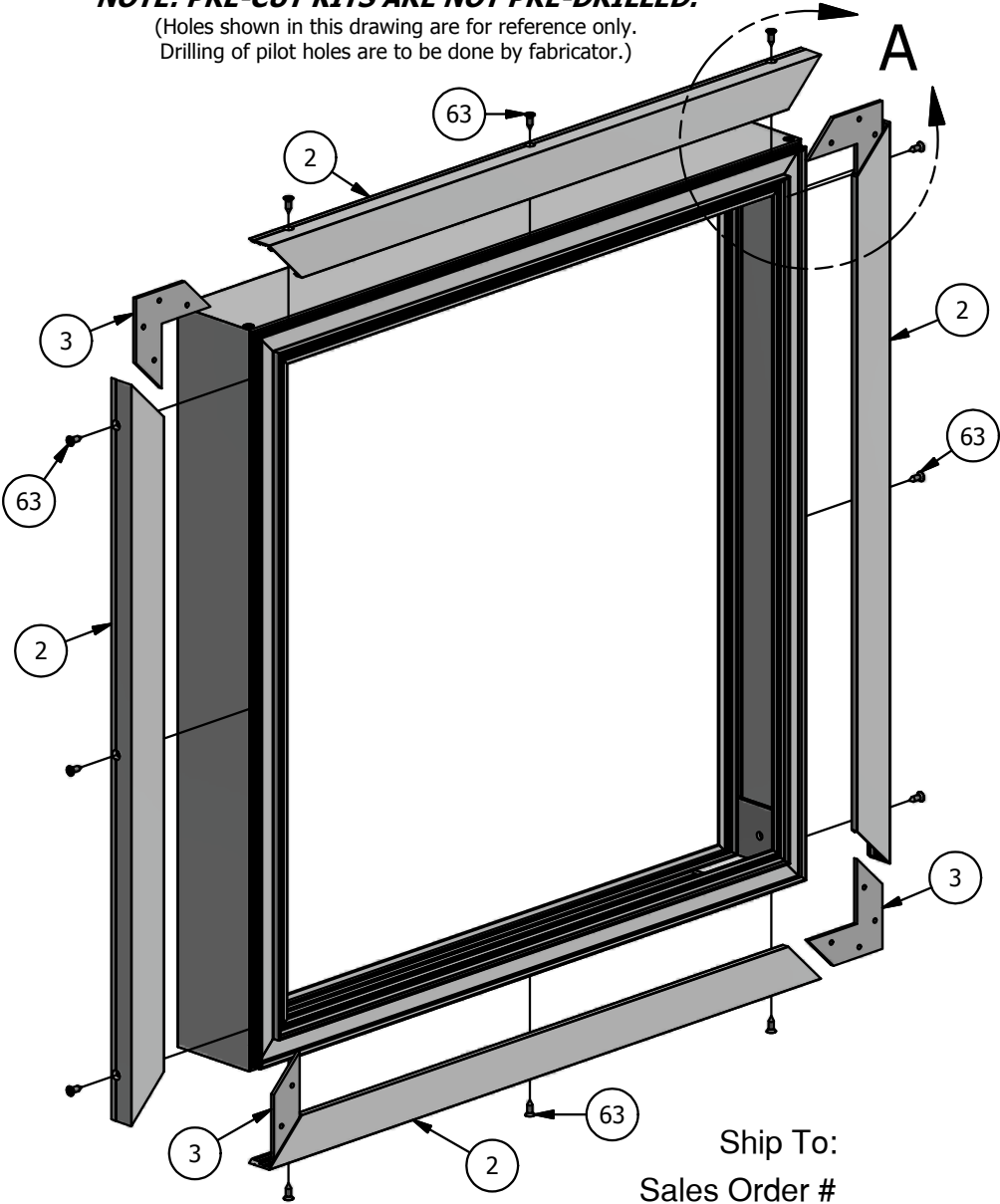

A

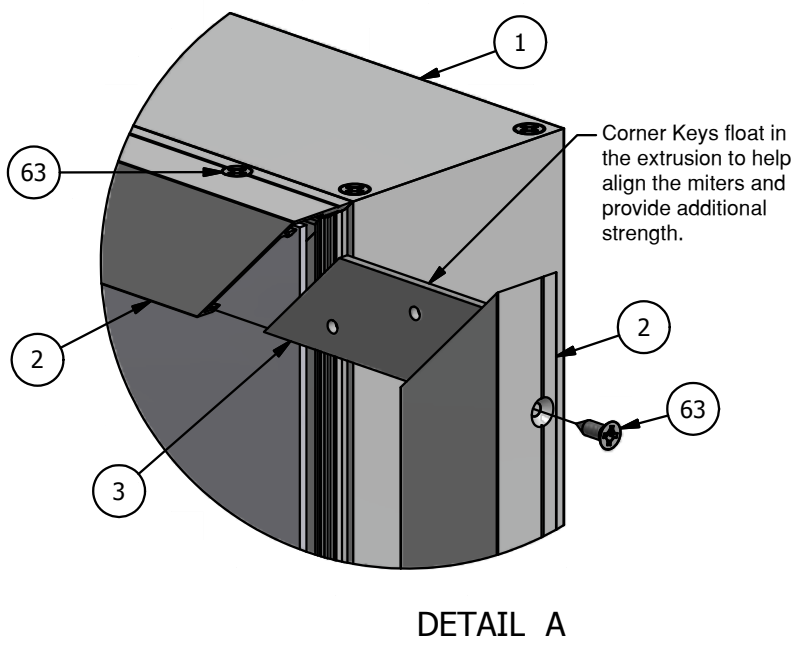

Ship To:
Sales Order #

2



1

THIS DRAWING WAS CREATED AT NO CHARGE TO ASSIST YOU IN VISUALIZING OUR PROPOSAL. THE DRAWING HEREIN IS THE PROPERTY OF SIGNCOMP. PERMISSION TO COPY OR REVISE THIS DRAWING OR TO USE THIS DRAWING FOR PRODUCTION IS STRICTLY PROHIBITED AND CAN ONLY BE COPIED, REVISED OR USED FOR PRODUCTION WITH THE EXPRESSED WRITTEN PERMISSION OF SIGNCOMP.

Project Name: **Series 4 SF Access Body w/ Slide Cover - Assembly**

Sign Company: **K1391/94**

Revision: _____

Date: **5/9/2017**

Sheet: **1 of 1**

Size: **A**

Drawing By: **SBreihof**



A

2



1

PARTS LIST

ITEM	PART #	DESCRIPTION	NOTES
1	K1391/94	Series 4 SF Access Body / Slide Cover	Assembly
2	1200	Series 2/3/4 Reveal	
42	5218	Reveal to Body Screw	Drill 5/32" pilot hole

NOTE: PRE-CUT KITS ARE NOT PRE-DRILLED.

(Holes shown in this drawing are for reference only.
Drilling of pilot holes are to be done by fabricator.)

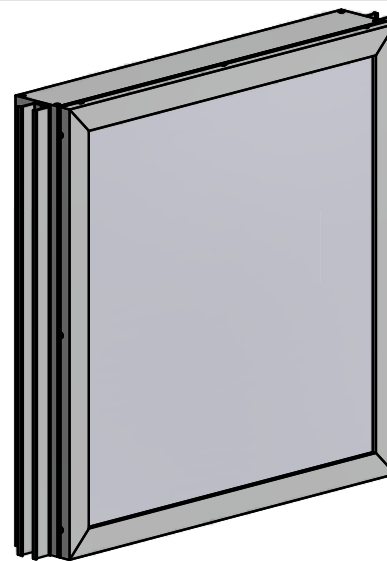

Ship To:
Sales Order #

B

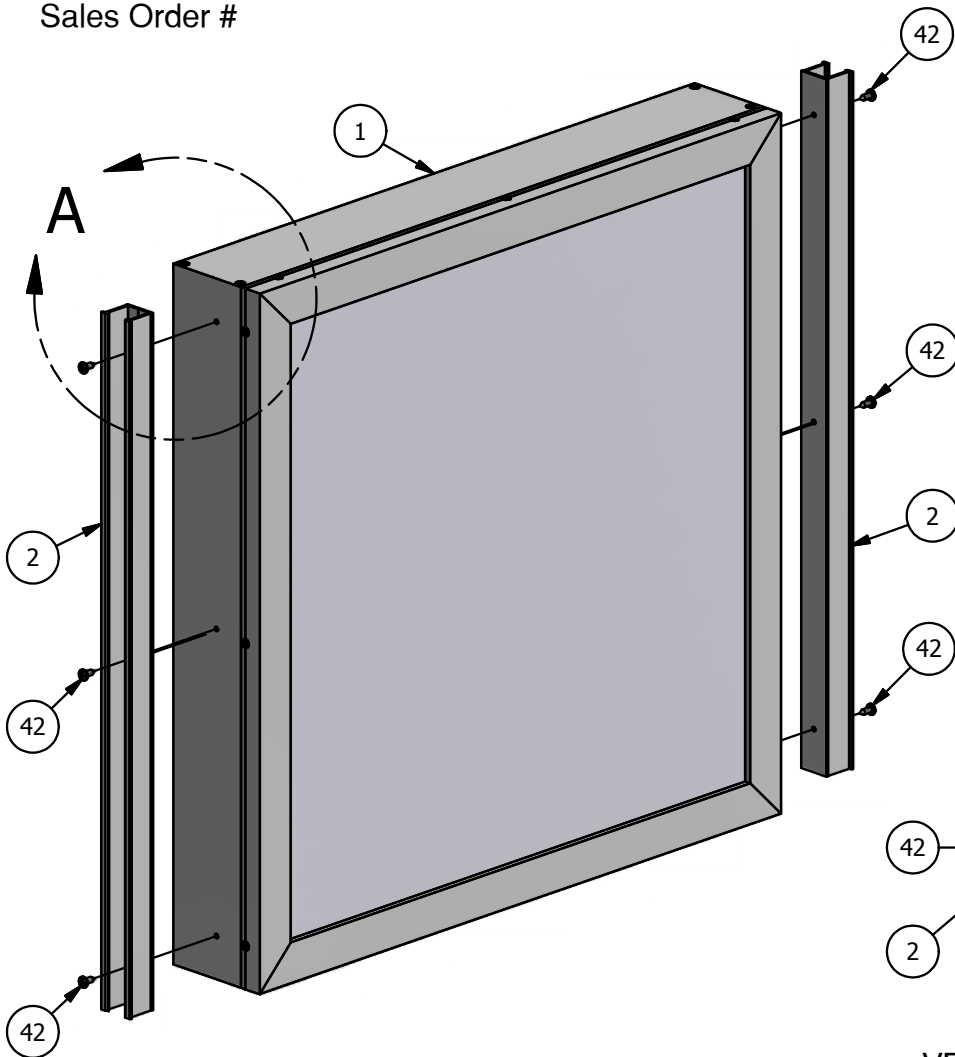

REVEAL IS FASTENED 1/8"
DOWN FROM THE TOP OF
THE CABINET TO ALLOW
FOR THE POST CAP

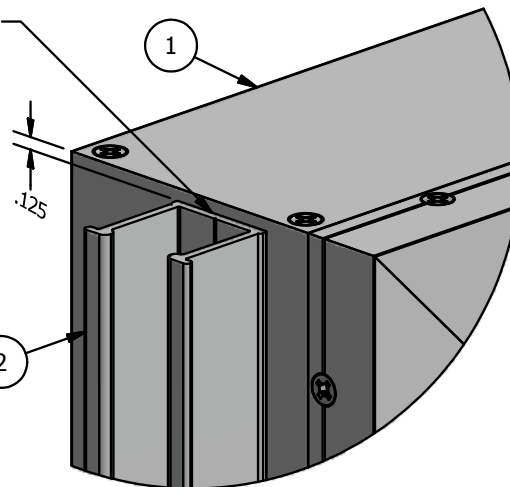

DETAIL A
ASSEMBLED

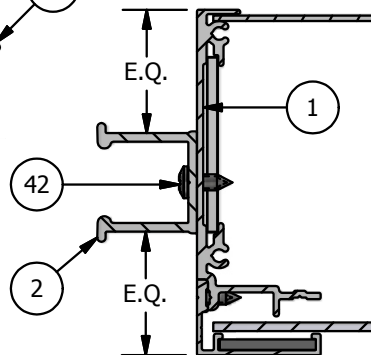

VERTICAL SECTION VIEW

2



1

THIS DRAWING WAS CREATED AT NO CHARGE TO ASSIST YOU IN VISUALIZING OUR PROPOSAL. THE DRAWING HEREIN IS THE PROPERTY OF SIGNCOMP. PERMISSION TO COPY OR REVISE THIS DRAWING OR TO USE THIS DRAWING FOR PRODUCTION IS STRICTLY PROHIBITED AND CAN ONLY BE COPIED, REVISED OR USED FOR PRODUCTION WITH THE EXPRESSED WRITTEN PERMISSION OF SIGNCOMP.

Project Name:	Series 4 SF Access Body w/Slide Cvr - Series 2/3/4 Reveal - Ass	Sheet:	1 of 1	Size:	A
Sign Company:	K1391/94 - Reveal	Revision:		Drawing By:	SBreihof
		Date:	10/24/2017		

B



A

PARTS LIST

ITEM	PART #	DESCRIPTION	NOTES
1	1333	Series 4, 4in Square Post	
2	1200	Series 2/3/4 Reveal	Tack weld or mechanically fasten to posts

NOTE: PRE-CUT KITS ARE NOT PRE-DRILLED.
 (Holes shown in this drawing are for reference only.
 Drilling of pilot holes are to be done by fabricator.)

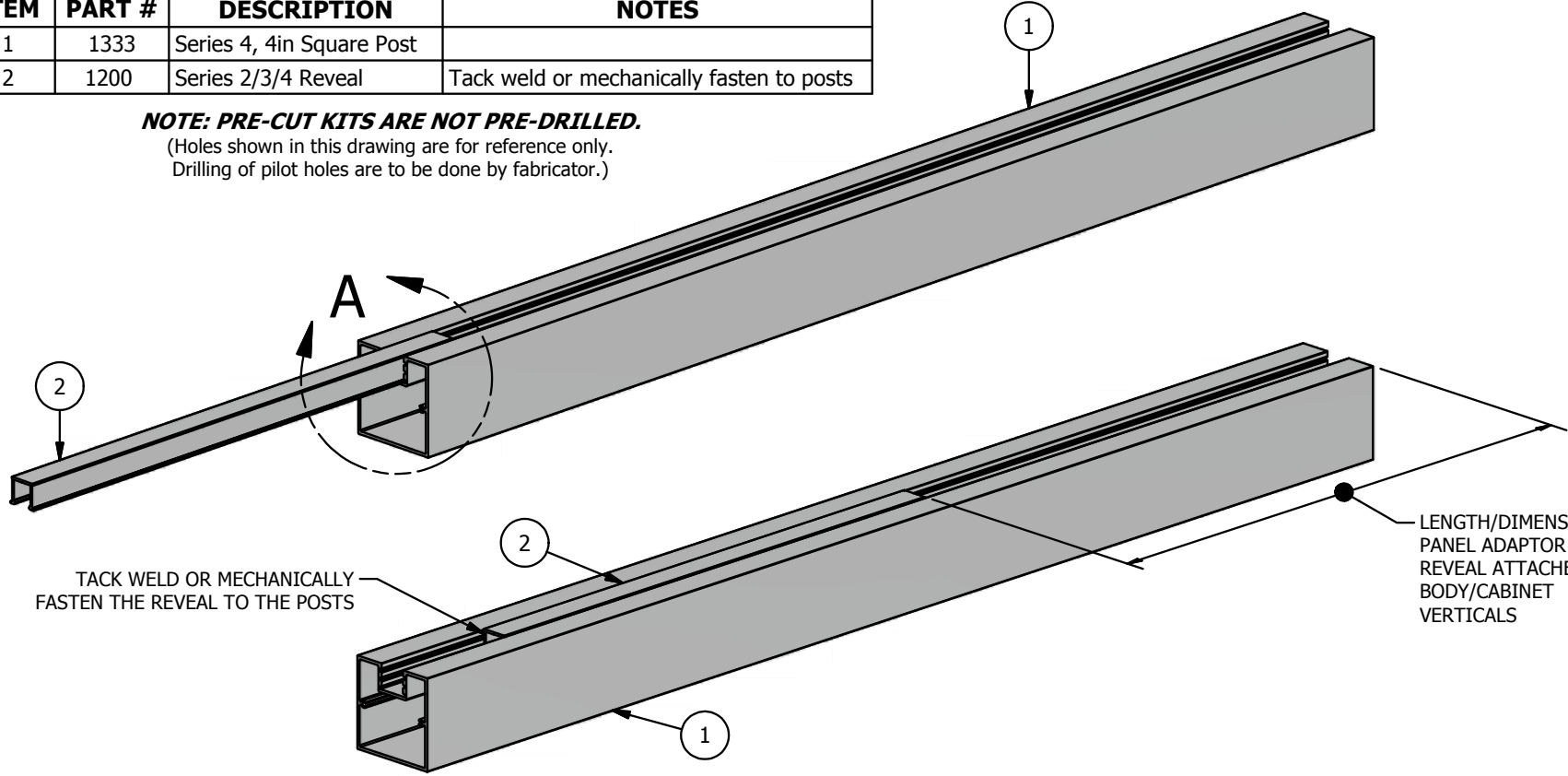

TACK WELD OR MECHANICALLY FASTEN THE REVEAL TO THE POSTS

LENGTH/DIMENSION OF PANEL ADAPTOR OR REVEAL ATTACHED TO BODY/CABINET VERTICALS

B

B

A

A

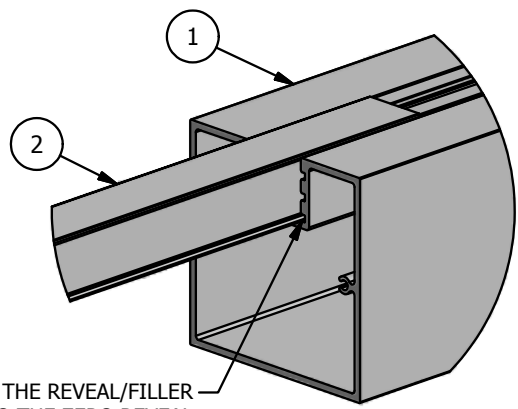

INSERT THE REVEAL/FILLER INTO THE ZERO REVEAL POSITION, THEN SLIDE IT INTO THE POST

DETAIL A

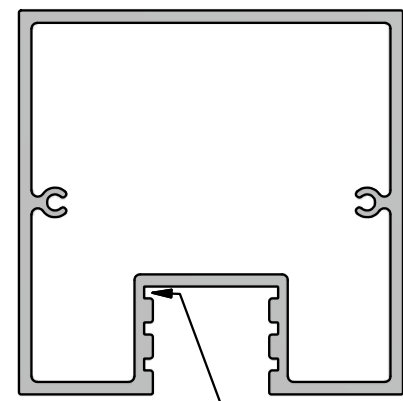

ZERO REVEAL

Ship To:
Sales Order #

THIS DRAWING WAS CREATED AT NO CHARGE TO ASSIST YOU IN VISUALIZING OUR PROPOSAL. THE DRAWING HEREIN IS THE PROPERTY OF SIGNCOMP. PERMISSION TO COPY OR REVISE THIS DRAWING OR TO USE THIS DRAWING FOR PRODUCTION IS STRICTLY PROHIBITED AND CAN ONLY BE COPIED, REVISED OR USED FOR PRODUCTION WITH THE EXPRESSED WRITTEN PERMISSION OF SIGNCOMP.

Project Name: Series 4, 4" Square Post - Series 2/3/4 Reveal - Assembly	Sheet: 1 of 1	Size: A
Sign Company: 1333-00	Revision:	Drawing By: SBreihof
Part #:	Date: 4/18/2017	



2

1

